

The Assignment

You are challenged to design a creative and sustainable housing solution, which will benefit a community of households, living in an area threatened by unpredictable water levels, or living permanently on water.

Final submissions could consider a number of possible solutions to the water problem. For instance: a permanent dwelling or a flexible demountable temporary dwelling that could easily be adapted to provide disaster relief for a location anywhere in the world.

Limitations

There are a number of project limitations you have to account for:

- The housing solution should have zero permanent impact on the natural environment. Zero housing concept
- Despite the ever-present threat of flood, the presence and conservation of water is a primary concern
- You will use new, sustainable methods and materials (no traditional protection methods such as dikes, dams or dunes)

Operation

You will work in a team with one or two students from the university of Halle and two students from the Gerrit Rietveld Aca-demie.

Program

The program of the floating dwelling is:

- A house/atelier function
- Only on two façades you are allowed to make windows or any other openings. One of the façades is the "fifth" façade or the is the roof façade

Maximum measurements

- The depth of your floating dwelling is 1.50 m-NAP related towards water level
- The height of your floating dwelling is 7.50 m NAP related towards water level
- The (w x l)= maximum 7 m x 10 m
- If you have a third floor, there is a floor limited of maximum 35 m²



Coaching

Tutors participating fulltime in the workshop:

- Dominic Balmforth, architect and lecturer at the Royal Danish Academy of Fine Arts, Denmark
- Professor Axel Müller-Schöll, architect, University Halle, Germany
- Assistant-Professor Jörg Hansel, University Halle, Germany
- Assistant-Professor Andrea Topanka University Halle, Germany
- Henri Snel, architect and head of Architectural Design at the GRA

Location assignment

Steigereiland-Noord at IJburg, Amsterdam (see site plan)

Water levels at the location

- Highest water level 0.00 m NAP
- Lowest water level 0.60 m-NAP
- Summer water level 0.20 m-NAP
- Winter water level 0.40 m-NAP
- The bottom of the water area is 2.70 m-NAP
- The pedestrian road/pier is on 1.10 m-NAP



Lecturers and Tutors

Henri Snel - After a lengthy career with renowned international architecture offices Henri started in 2001 the office Snel-Architecture: an office for Architecture and Interior Architecture. The core of his work consists of the design of buildings, interiors and furniture for a variety of uses. At the base of each task, the development of a clear concept whereby the relation between architecture, program, sustainability and budget is central.

Beside this Henri Snel lectures at different institutions in the Netherlands, amongst others the Gerrit Rietveld Academy. He experiences teaching as a valuable supplement to his professional practice. Henri Snel studied interior Architecture at the Gerrit Rietveld Academie and he did his Master study Architecture at the Academy of Architecture in Amsterdam.

Axel Müller-Schöll studied architecture, interior design and furniture design at the Academy of Art and Design Stuttgart and at the University of Florence. After various teaching activities in Stuttgart, Lyon and Beijing, he became 1994 a Professor of Designing Interior Architecture/Interior Fittings at the Burg Giebichenstein University of Art and Design Halle (BURG), where he founded the idea... Institute (Interior Design Environment and Architecture).

He is working also with his Studio Paretaia (www.paretaia.de) in Stuttgart. Activities have so far included building, interior design, exhibition architecture, furniture design as well as consulting companies in the field.

Dominic Balmforth - Employed at Henning Larsen Architects (HLA), Copenhagen from 1999 to 2005, Dominic was involved with diverse competition projects ranging from large scale buildings to urban planning. These included the winning entry for ITU, IT University, Ørestad, completed in 2002 and awarded 'best new building in Europe' by LEAF (Leading European Architect's Forum) in 2005. Dominic worked as key designer for the main auditorium for the Danish National Opera house from 2001 to 2003 and project architect for the Kennet Valley Park Project, a sustainable masterplan for 7500 new homes outside Reading, UK, from 2003 to 2005.

Dominic joined London based sustainable consultancy practice, Beyond Green in 2005 working as their inhouse architect on a sustainable townhouse prototype, a sustainable primary school for Islington Council, a 1000 home masterplan for New East Manchester, and a series of land-use strategies for North-umbria and Essex Water Company.

Dominic currently manages his own design and consultancy practice working with both small scale design solutions and large scale sustainable planning strategies. In collaboration with Hannover based practice, CITYFÖRSTER, Dominic was recently awarded 3rd prize in a regional planning competition for 'Øresund 2040'; future visions for the Øresund region.

Dorine van Hoogstraten is architectural historian. She writes about Dutch architecture and urban planning since 1900 and works as and advisor on preservation and re-use of historic buildings. She published articles and books about the Dutch architects Dirk Roosenburg, Ernest Groosman and John Habraken and the Amsterdam neighbourhoods IJburg, Zuidoost and Zuid, and several other subjects. Since 2006 she teaches architectural history and theory at the Gerrit Rietveld Academie. www.dorinevanhoogstraten.nl

David Balmforth is a Technical Director with international consultants MWH. His work at MWH covers urban flood control, flood risk management and climate change adaptation.

Formerly as an academic, he established an international reputation for research in urban drainage and pollution control. He has over 50 journal and refereed conference publications to date, and he is currently a visiting professor at Imperial College, London.

His recent work includes the technical direction of major programmes of flood control and pollution control for Southern, Thames, Yorkshire and Northumbrian Water and United Utilities in the UK. He has contributed to the UK Water Industry Research programme on Climate Change and the Performance of Sewerage Systems and the UK Government's Foresight Project on Climate Change, Flooding, and Coastal Defence and is currently engaged in Integrated Urban Drainage Pilot Studies for UK Government. He is currently advising UK Government on last summer's floods. During 2007 he spent time working in the US promoting climate change adaptation strategies for water supply and flood control in Denver, New York, Seattle, Chicago and San Francisco.

David is also a Director of the Construction Industry Research and Information Association, a member of Council of the Institution of Civil Engineers in the UK. He is also and Editor in Chief of the international Journal on Flood Risk Management, published by Wiley-Blackwell.

Jörg Hansel - After his vocational training as a metalworker, private studies about clay construction and courses of electrical engineering he studied Interior Architecture at the Burg Giebichenstein University of Art and Design Halle (BURG). Graduated in 2002, he directly founded his own office and works as a freelancer. Key aspects of his activity are biological, material- and cost-conscious constructions (clay) and sustainability. Furthermore, since 2004, he works at the workshops of the Burg Giebichenstein as a specialist for several materials, especially plastics.

Clemens Nuyens studied architecture at Technical University in Delft (NL) and ETSAB, Barcelona (E), graduated 1990. During his study he worked for Mecanoo architectural office. After graduating he lived in Barcelona and worked a.o. for Beth Galí. Back in The Netherlands he worked for the City of The Hague, B+B office for landscape architecture and project office Ypenburg in The Hague. Since 2000 he is senior urban designer at the Physical Planning Department of the municipality of Amsterdam. Here, he worked on the plans of the waterfront development on both sides of the IJmeer lake. At this time he works on Steigereiland, IJburg, a new residential district constructed on artificial islands in the IJmeer lake and is involved in the making of the Masterplan Almere Pampus. Furthermore, he is member of the Committee of Monuments ARK in Leiden.

Bart Truijens - After finishing his architecture studies in Amsterdam in 1982, Bart Truijens worked for 10 years at various architecture offices in The Netherlands. After that he became a staff member at an Amsterdam housing corporation. Since 2000 he works for the City of Amsterdam, at the Development Corporation. Here, he is consultant for sustainable architecture, DIY-constructing on land and water, and quality of living on IJburg, the new residential district constructed on artificial islands in the IJmeer lake. He is the author of a handbook on sustainable DIY-constructing.

Andrea Topánka - After her vocational training as a joiner she studied Interior Architecture at the Burg Giebichenstein University of Art and Design Halle (BURG). During this time, she gained international experience in the Netherlands - at the Academy of Fine Arts and Design Enschede as well as during an internship and working period at Concrete Architectural Associates Amsterdam. Since her graduation 2007, she works as a freelancer for young offices (building, interior and furniture design) in Halle and Wittenberg. In January 2008 she became the assistant of Professor Axel Müller-Schöll at the Burg Giebichenstein

Group 1

Jody Vergeer
Vineta Du Toit
Manon Maatje
Selma Kaufmann

Group 2

Robbert van Embricqs
Maryana Gudziy
Bin Xu

Group 3

Luca Salas
Gabor Disberg
Li Wang
Barbara Steidl

Group 4

Jimmy Faber
Kristin Maurer
Ivo
Franziska Mundt

Group 5

Nadin Bastian
Peer Frantzen
Marian Stefan
Tieke Hentenaar

Group 6

Anne Schaufuss
Floris Leenders
Sang Yong Lee
Edina Nemeth
Martino Morandi

Group 7

Diana Cerrada Maeso
Arna Mackic
Luise Wegehaupt
Elisabeth

Group 9

Maya Bannink
Chris Bakker
Jolanda van Goor
David Oehme

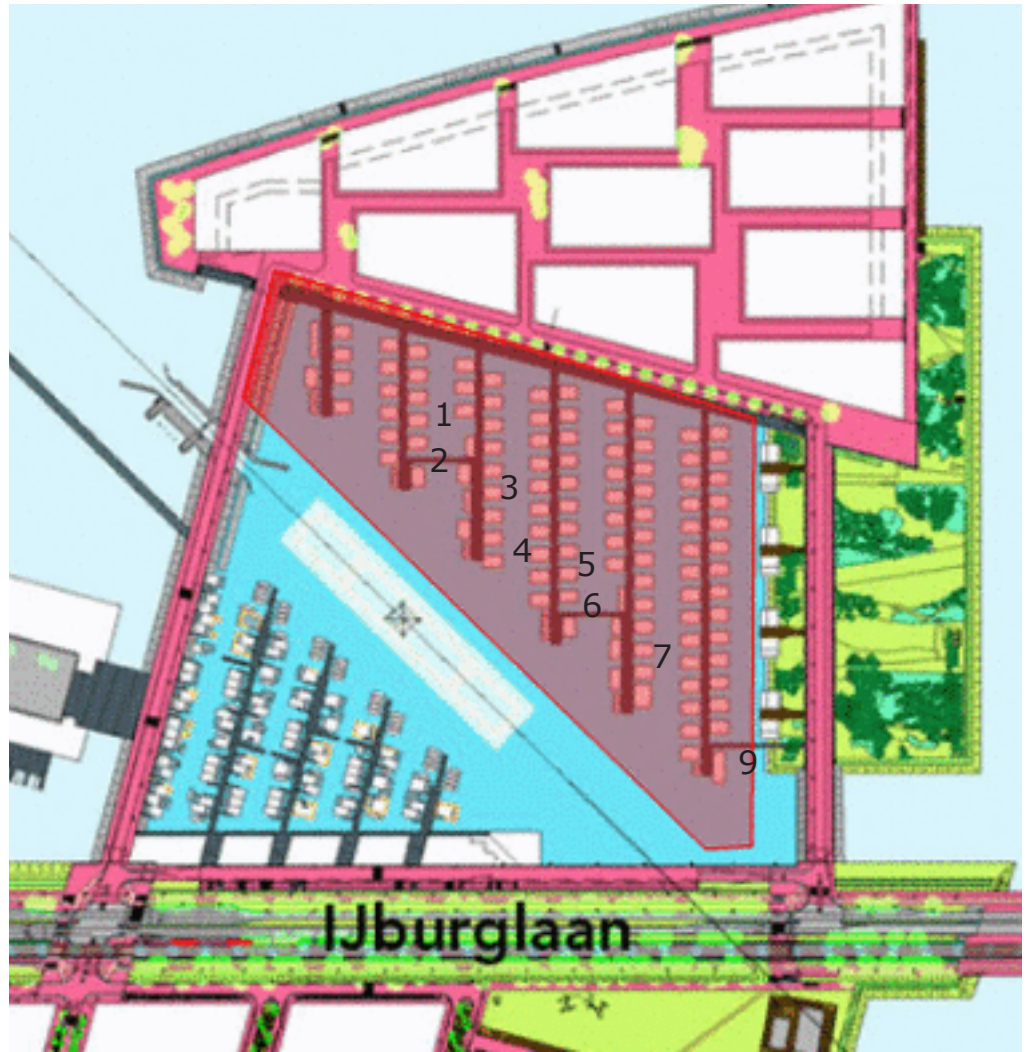

The boathouse was designed to fully use the advantage of being situated at the end of the pier. Direct sunlight is easily obtained and there is social possibilities because of the view over the area.

The concept was to combine public space with private quarters. Therefore a tribune shaped public "piazza" was designed as extension of the pier to which the house is attached. The tribune creates a inner harbor and reinforces the shape of the house.

The role of sunlight was also a important factor during the design process. The shape of the house is based on the movement of the sun and lets in optimal light through the south façade.

Suspense is also absent in the design. When approaching the end of the pier one is faced with a very closed, solid façade until turning the corner. Then one is faced with totally the opposite of what is expected. An open, welcoming gathering place where one can enjoy the beauty of the area. There is also suspense in the interior design of the house because the pier obscures the view from the basement. A different affect is reached in different locations in the house when looking into a Northern direction. The higher lever one reaches in the house, the bigger the view of the area.

The sleeping room and bathroom is in the basement with light entering through the stairway opening. On the first level is the kitchen and living room. The upper floor is a free space.

Sustainable solutions taken into consideration is solar panels on the roof, indirect heating through the walls, use of local materials and having the south façade open. Social sustainability was also inherit in the design. The boathouse was designed to bring people together to interact and appreciate nature.

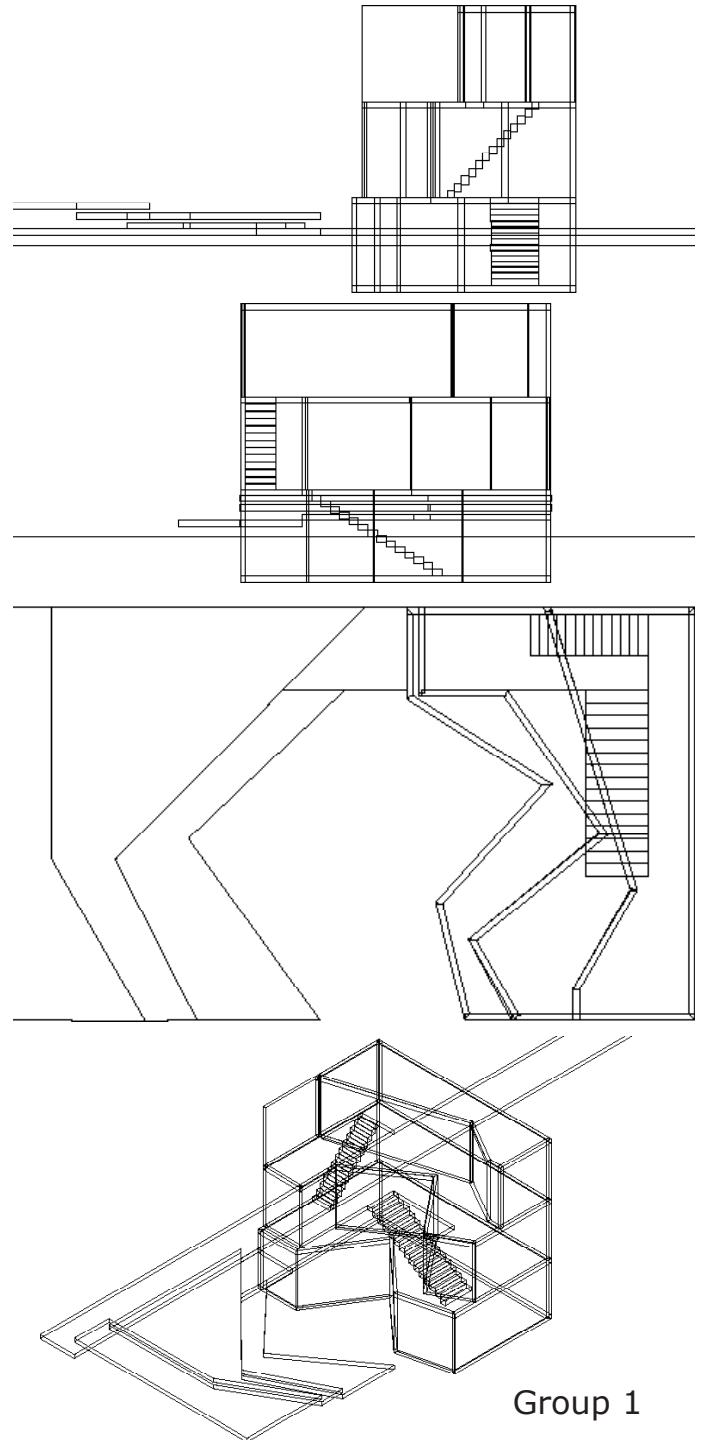

Group 1

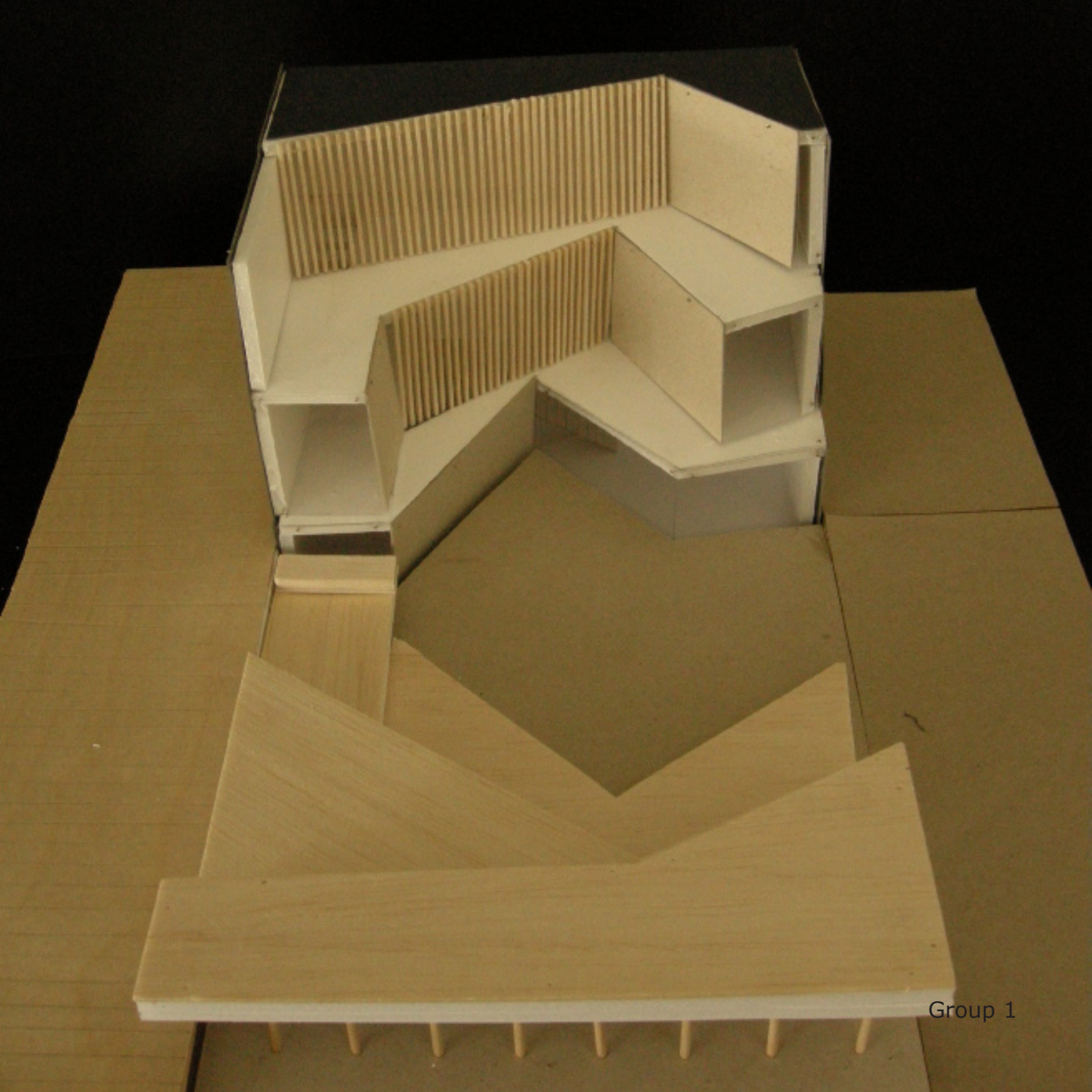

Group 1

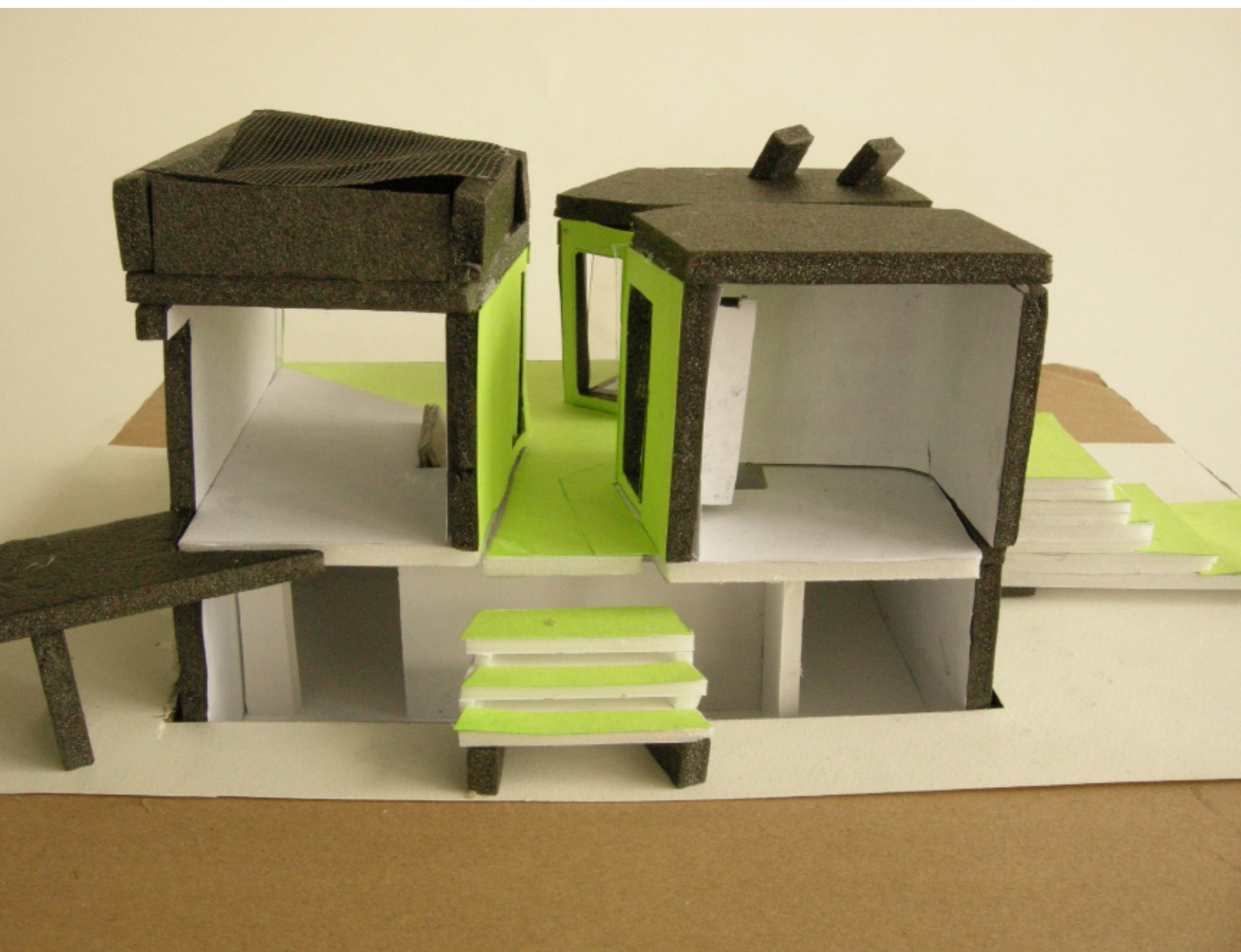

The main concept about this floating house was how people could use the whole space differently in the different seasons throughout the year.

Each room on the upper half of the deck is divided into different sections. Therefore we created private rooms that could be used by the people. The front section is made for the use as a studio. The space behind the studio can be used as a sleeping room. The largest upper space is made for the living room. All the rooms have windows that are facing the open water.

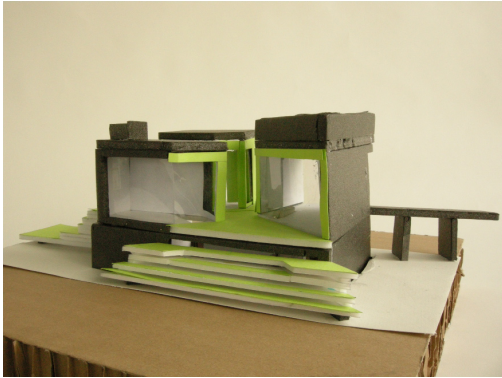

In the summer, people have the opportunity to use the open corridors between different spaces upper deck to move from one to another space. The walls of this open corridor has growing plants everywhere what gives a natural surrounded feeling (that's what the green colour stands for) Facing south you have an open triangle, large enough to put chairs on . There-

fore people can sunbath or use the stairs against the floating house that is part of the open corridor and the triangle.

When it is cold in winter the people can use the stairs that are made in each separated space and they come together below deck. there you have the kitchen that has a window behind the outside stair that is constructed against the boat. You will also find the bathroom, the toilet and storage space below deck. For the sustainable solution we integrated a water tank for rainwater on top of the living room. Also solar panels are part of the roof on top of the studio.

Each season the floating house will have his changes in use, like its natural surrounding.

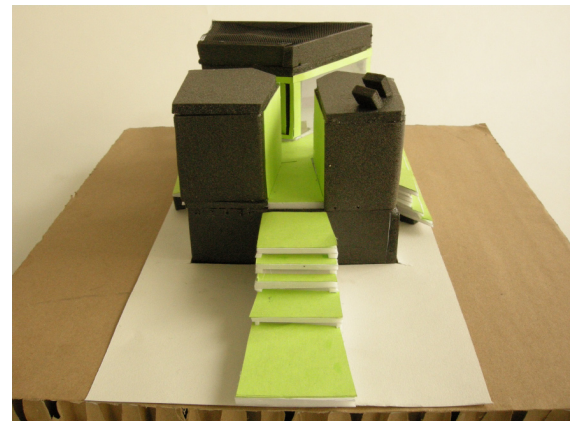

Group 2

Our project is based on 3 levels of sustainability;

Light and natural ventilation

Using the light and air we need. We started from a form, based on a 3-level house. We shape it for creating entrance of indirect and direct light and having horizontal openings for the ventilation.

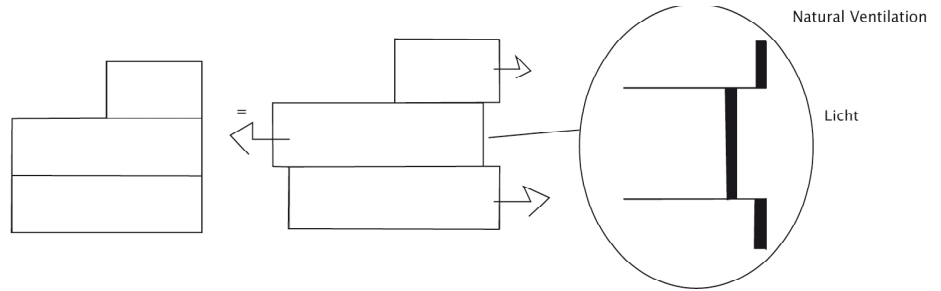

Space management

The use of the space. A sustainable house with two different uses for summer and winter. On which the stairs gather the facilities of traffic, plumbing, kitchen, toilet/ shower. The use of the spaces are in conformance to the need of the user, in the sense that the office can be used as a sleeping place and vice-versa.

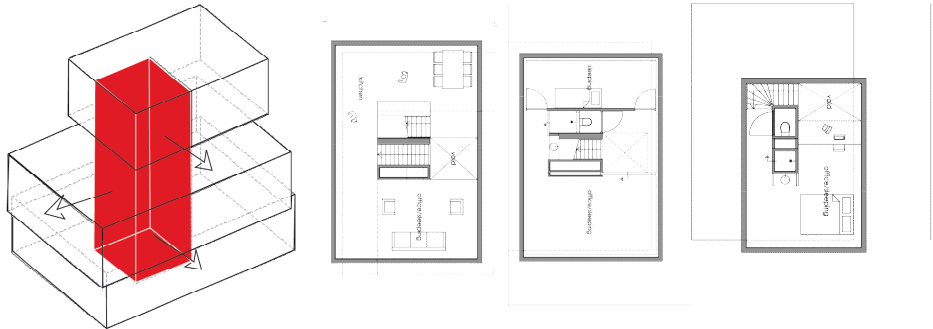

Solar energy and rain water recollection

Using the sustainable solutions of solar panels and a system of recollection and filtration of rain water we add to our boat house an independent function concerning water and electricity. These two sustainable solutions are located in two different levels of the house. The solar panels are on the top roof gathering the much light possible. The rain water recollection system is on the roof of the middle floor of the house, having a lot of space for storing and gathering.

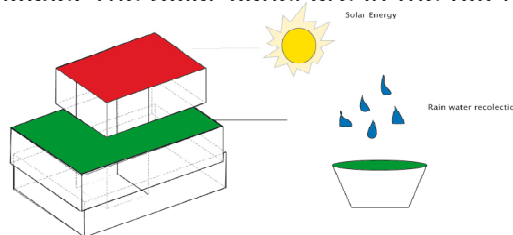

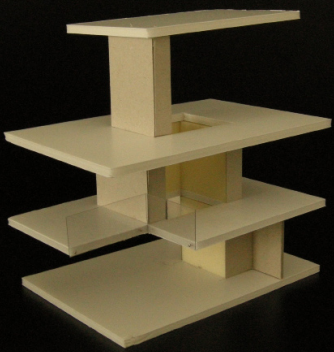
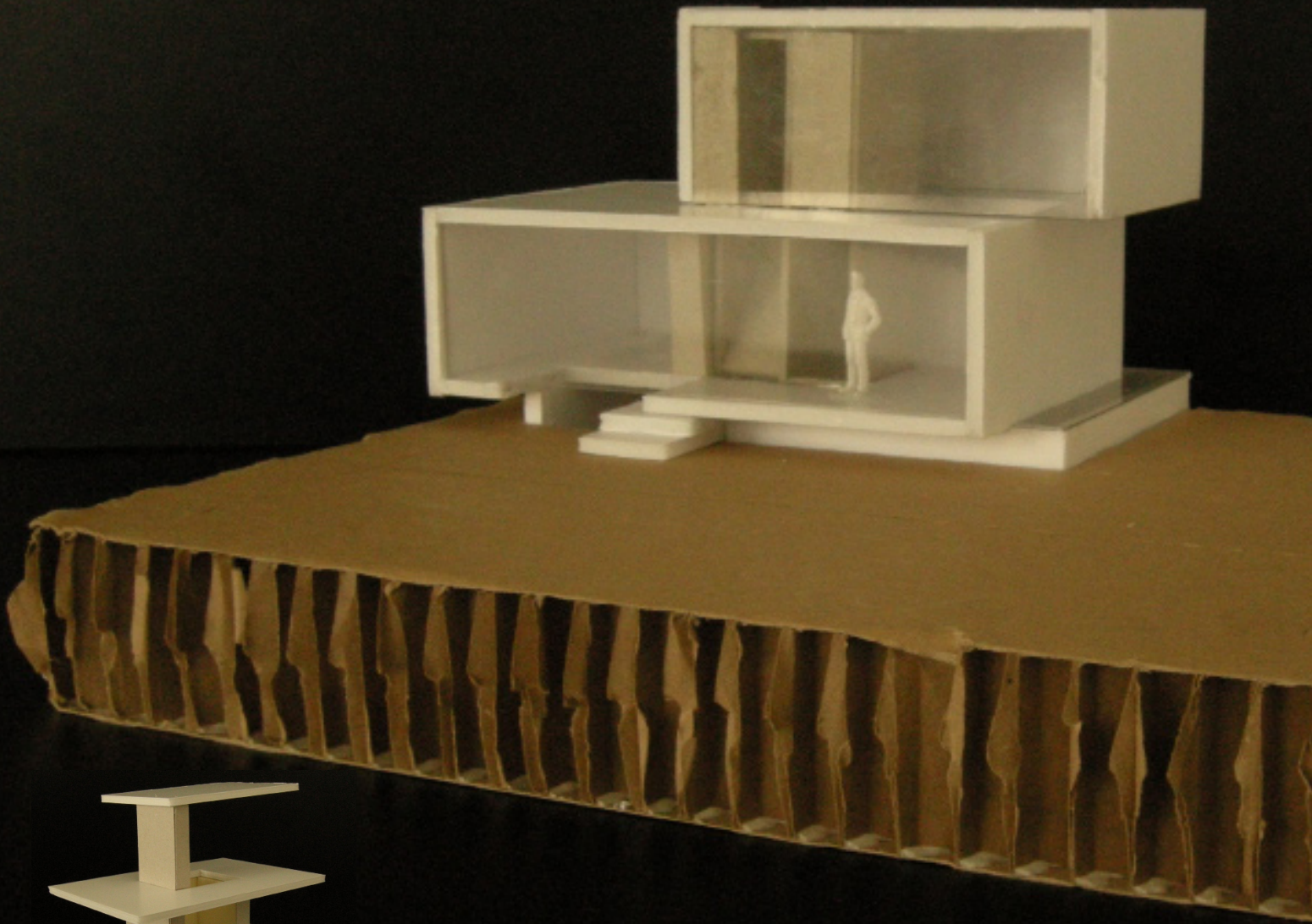

Group 3



Group 4

Key elements:

- Original shape of 7x10 m is transformed into cubic shapes and cut out and twisted around the basic floor plan.
- The house is divided into two areas, working and living. Part of the house is underneath the pier and the water.
- The big staircase in the middle, through the whole building combines the two areas and brings light into both sections, that work as a shaft, as well as the heating of the building.
- Through the cutting and twisting arise gaps and strokes, little platforms around the house, to sit on, with a grill to walk on or unreachable, only for light and greenery.
- All light strokes are at least 50 cm broad so that the daylight can shine in and light up the walls inside, direct and indirect light

Movement system:

Routes are through the building using the staircase with two entrances.

Light system:

The light comes through shaft and in the shaft are hanging prisms.

The prism gives a maximum use of the light.

Through the light strokes

The sunlight comes from the west.

The reason is that the sun warms up the south walls, which gives a warmth accumulation.

Warmth system:

Sun used for warming the South walls ventilated into the house.

On the rooftop are solar cells for supporting electricity.

Ventilation system:

All doors are glazed and together with the windows they have grilled openings on the bottom for ventilation.

The basement has ventilation in the walls.

The reason for the ventilation in the basement is to support the building with warmth.

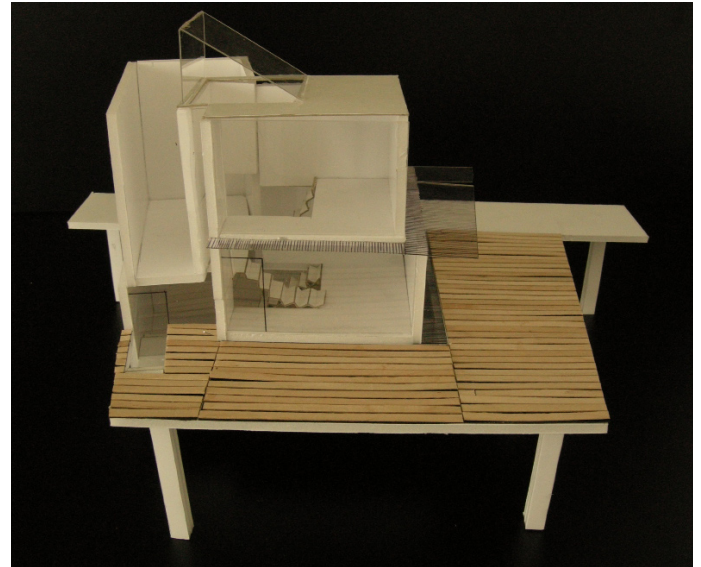

Conclusion:

The staircase is most important element, it support sustainability, shuts as light and warmth. Axis through the building, combing the two spaces.

The house consists of two floating modules, of which one forms a protective skin for the other. The Greenhouse and the living house. These can be moved and turned independently of each other. Giving the possibility of four different configurations. The Greenhouse forms a bufferzone. This keeps the heat in, in winter. In summer the difference in temperature between surface water and air can be used to ventilate and cool the inner module and in-between space.

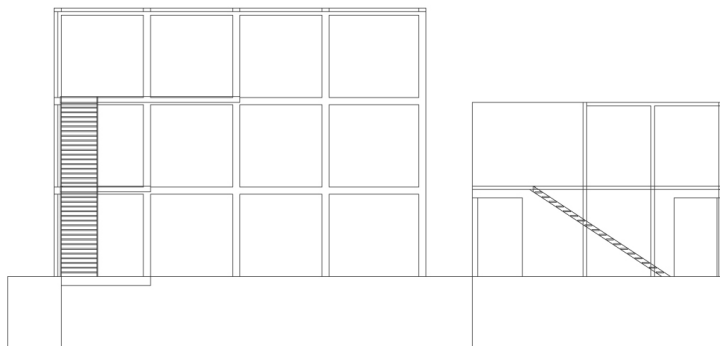

By moving out the inner module the surface area can be doubled, and putting it back in a different configuration gives the possibility to make a more open or closed space, in terms of light, water and privacy. The transition from outside to inside space becomes more gradual. A play of light and reflection is in this way evoked.

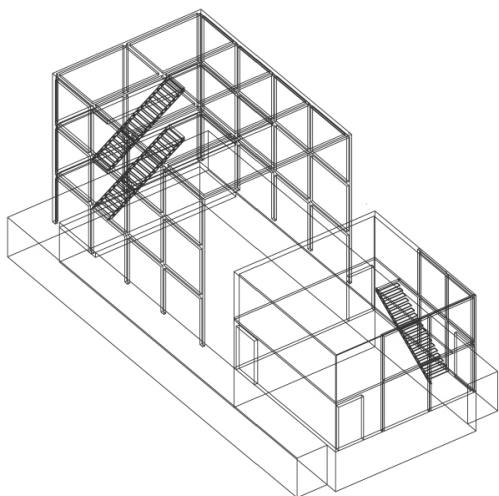

The functions of the house are centered around one or two inhabitants. The interior is divided between a living area and atelier. In the greenhouse there is space for exhibitions.

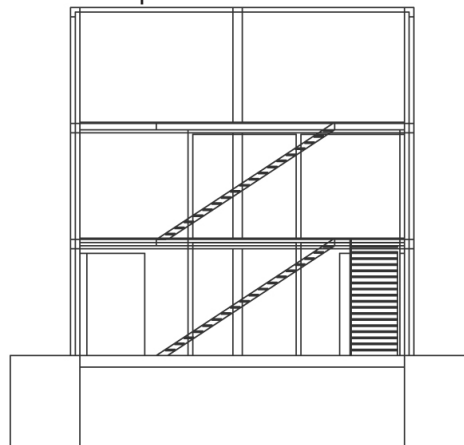

Sustainability:

- efficient use of energy
- efficient use of environmental conditions.
- Efficient use of water
- natural cooling and heating
- sustainable materials

Materials: Greenhouse

- iron structure
- polycarbonate plates

House

- polycarbonate
- sustainable harvested wood

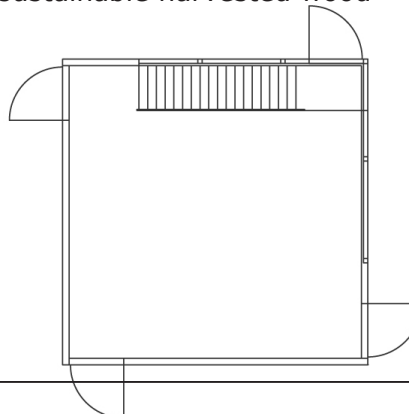

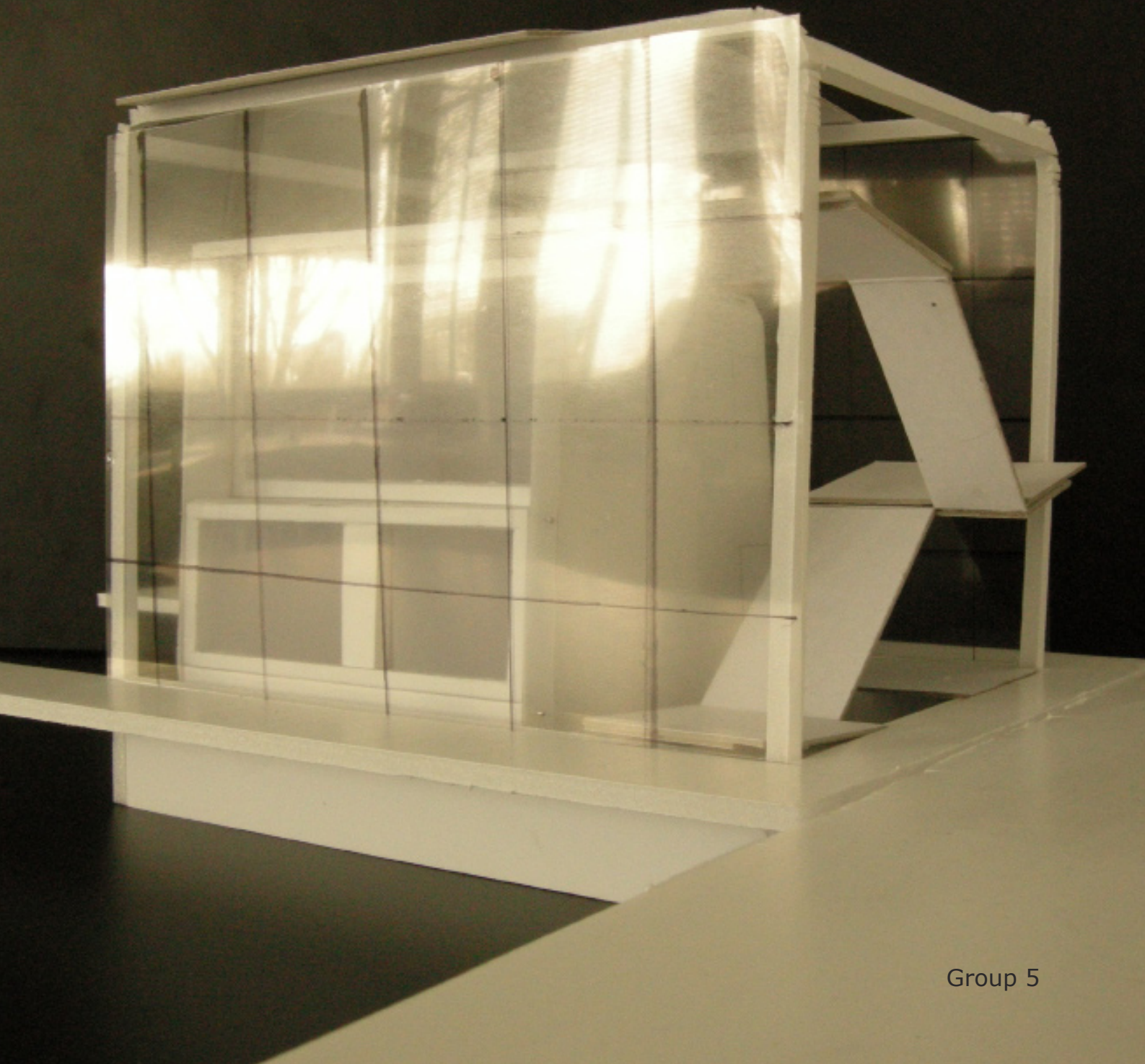

Group 5



Group 6

Sustainability

- Reusing Materials (lightweight materials), using local materials (selection e.g. bamboo/scaffold..), so the concept could work world-wide.

- Dividing the "7x10-cubes"
Creating several facades in order to get more light into the building/to build more functional surfaces for solar panels etc.

- "Neutral rooms"
Giving possibilities to change rooms of similar size (atelier <-> living room) according to the lifestyle and situation of the family.

- Steep roofs with plants
Collecting and filtering water for the toilet, shower, kitchen and garden.
Giving back green/neutral surface (biotope) to the environment.

Consciousness of the residents regarding the ecological systems can be stimulated by making natural contexts visible.

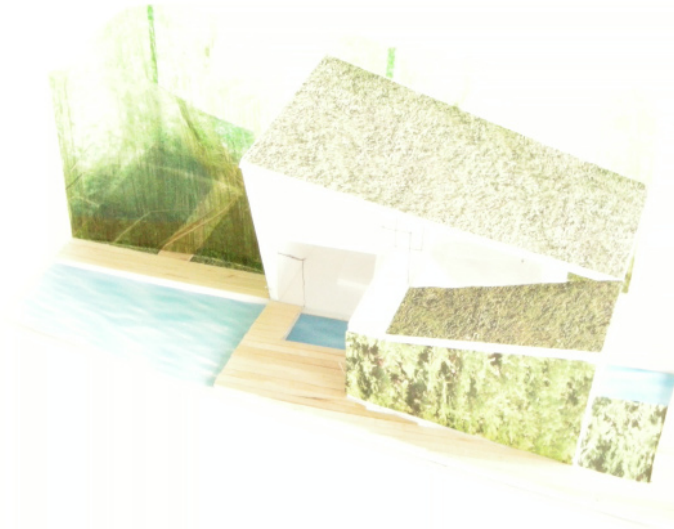

We have designed a wooden boathouse for two persons. The boathouse is designed for the persons to live and work in. It is also designed to be sustainable.

The main concept is an inside-outside garden. The garden starts outside and when you enter the house the garden continues as a carpet towards the center of the house. There it turns into a vertical garden and goes up to the first floor. This vertical garden is situated centrally through the whole space and the interior organization is based around the vertical garden. The balcony also has a garden. All this greenery in and around the house is also part of the sustainability. It brings fresh air into the house and the surrounding. It is also good for the birds that are living in that area.



Another sustainability part of our design are the windmills on the roof. These windmills define the shape of the building because we had to put them in a way that the wind can go the best way through the turbines. As a result of this, the roof takes a curved shape. The windmills generate the necessary energy for the house.

We tried to make the spaces in the house as open as possible. When you enter the house you first see the living area with the kitchen behind it. Next to the kitchen are two smaller spaces: the storage room and a technical room. From the kitchen we created an enclosed corridor with the vertical garden where you can walk to the bathroom and the stairs. Upstairs is a bedroom and a working space just divided with a screen. From the spaces upstairs you can also look out over the living space. We did this because it makes the house more spacious and the people living in it will have a connection with the living space while working. From the working space is a walkway to the balcony, where you have a nice view over the nice area of IJburg.



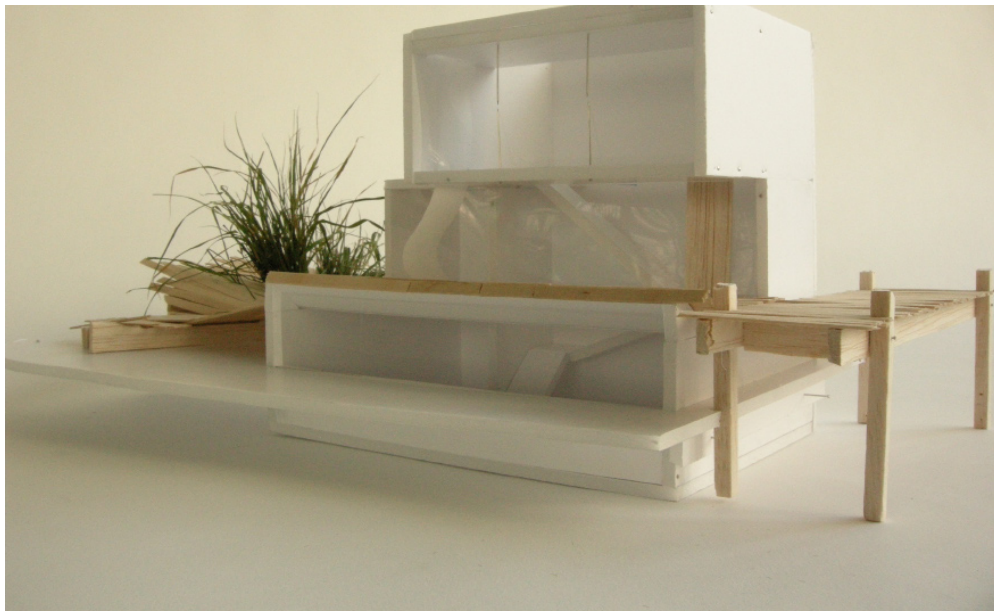

Group 9

- CONCEPT:**
- Combine design with eco
 - Living and working space
 - Separate space for technique
 - Living on the water
 - Public garden/plateau

- DESIGN:**
- 3 compartments, each a different function
 - Part of watering filter system intergrated in the plateau
 - Plateau consists different layers to move separate from one another

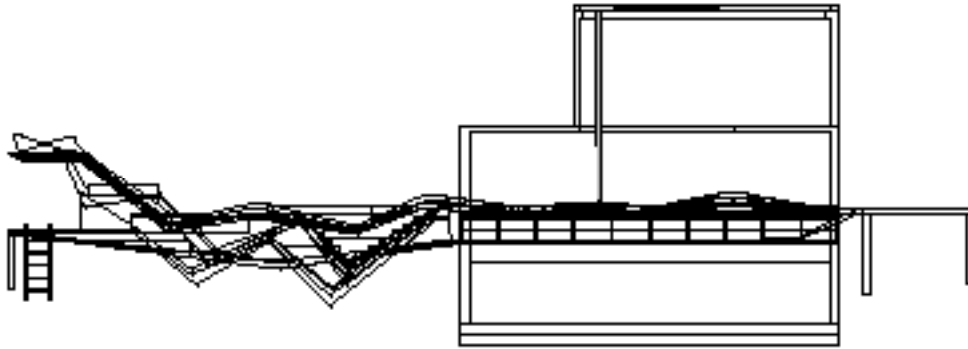

- SUSTAINABILITY:**
- Life sustainable
 - Possibility to share
 - Water filtering system

- MATERIALS:**
- House: steel/concrete construction
 - Plateau: wood
 - Glass

University of Art and Design Halle

Department: Interior Architecture

Burg Giebichenstein

P.O. box 200 252

06003 Halle/ Saale

Tel +49 [0]345-7751-802

Fax +49 [0]345-7751-805

Coordinator: Prof. Axel Müller-Schöll

email: mueschoe@burg-halle.de

Gerrit Rietveld Academie

University of Art and Design

Department: Architectural Design

Frederik Roeskestraat 96

1076 ED Amsterdam

tel: (31)20 5711600

fax: (31)20 5711654

Coordinator: Henri Snel

email: h.snel@rietveldacademie.nl

April 11, 2008 Amsterdam



„The colours are a-changin’!“